

Flexure Gauge

A new universal flexural element for high precision dimensional measurements

Datasheet
502623
Issue 2.1

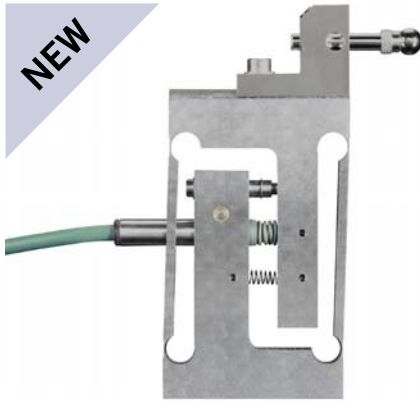

Features

- 2 mm Measuring Range
- Extended Operating Life: > 25 Million Cycles
- Excellent Repeatability: < 0.10 μm
- Digital, LVDT and Half Bridge
- Spring and Pneumatic Operation
- IP65 Protection
- All Stainless Steel Construction
- A selection of Tips

Description

The Flexure Gauge is Solartron Metrology's solution to the need for consistently high precision dimensional measurements.

As a compact, frictionless parallelogram device, the gauge does not suffer from the wear usually associated with bearing systems. It is equipped with range stops to avoid displacements above the yield stress of the material and is therefore capable of achieving tens of millions of measurement cycles. The integral transducer is fitted with a Viton[®] gaiter to achieve IP65 rating and the absence of bearings makes the Flexure Gauge naturally immune from contamination and humidity.

The Flexure Gauge has forward and reverse spring action with a pneumatically actuated version available for automatic measurements. It is supplied in analogue form for plugging into most standard amplifiers and Orbit[®] digital form for improved linearity over the whole measuring range.

The tool mounting assembly can be variously adjusted along the gauges length and fixed with M3 bolts. A selection of tips is offered to suit each application.

Mechanical Drawing

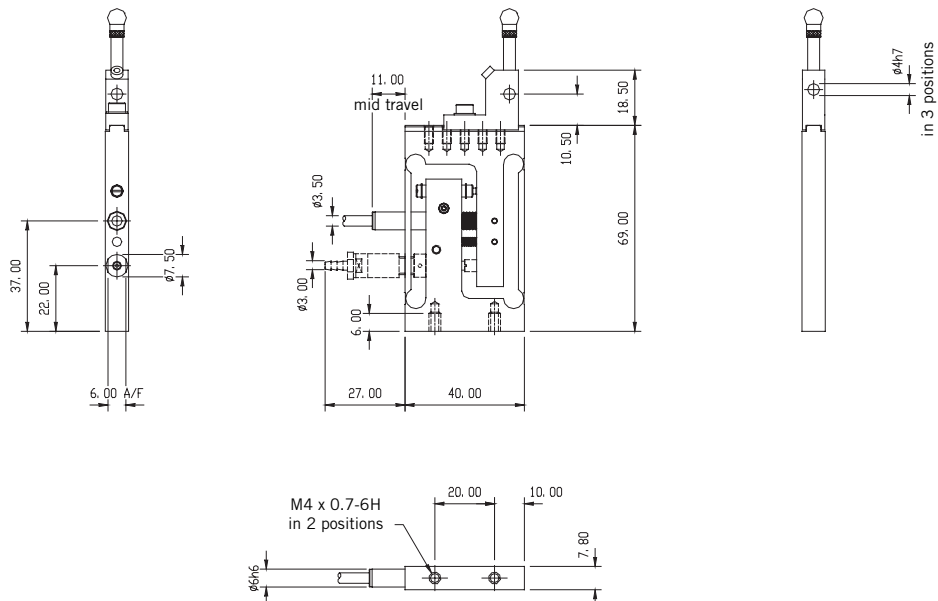

Flexure Gauge general outline. A detailed drawing is available to download from www.solartronmetrology.com

Applications

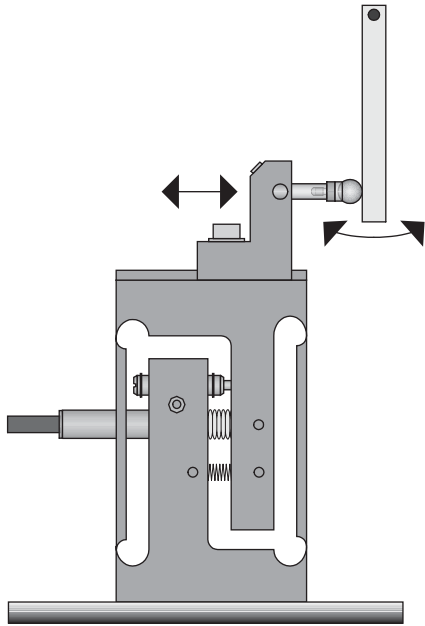

Zero hysteresis bi-directional measurements

Gauging of precision formed components

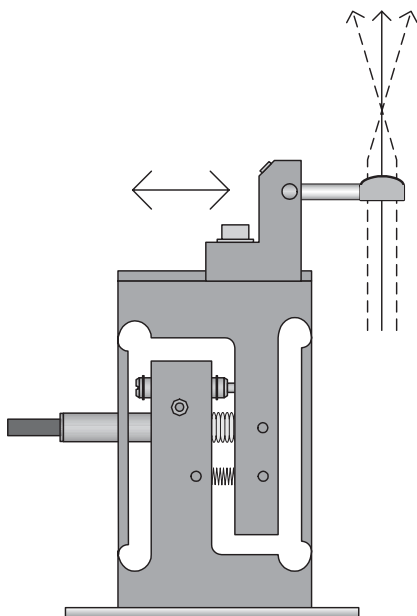
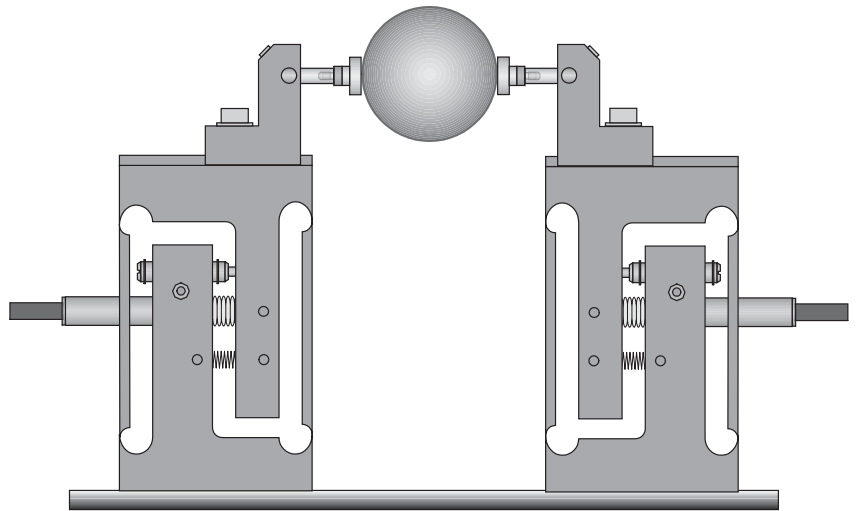

Precision positioning applications

Technical Specification

Measurement

	Analogue	Digital
Mechanical Travel	2.5 mm	
Measurement Range	±1.0 mm	2 mm
Linearity ¹ (includes both linearity & sensitivity error) D: distance from setting master	±1.0 µm ±D x 0.5% at 5 kHz for LVDT at 10 kHz for Half Bridge	±0.1 µm ±D x 0.1%
Repeatability	< 0.1 µm	
Resolution	Dependant on associated electronics	User selectable to < 0.1 µm
Null Position	Adjustable throughout the travel	Not applicable
Tip Force (in horizontal attitude ±20%)	1.5 N at mid position (spring operation) 1 N at mid position at 2 bar (pneumatic operation)	
Temperature Coefficient	< 0.01% of Full Scale Output per °C	
Life	Better than 25 million measuring cycles (dependant on application)	

Mechanical

	Analogue	Digital
Mass (less tool holder)	120 g	
Mass of tool holder	12 g	
Material	Stainless Steel with Viton® Gaiters	
IP Rating	IP65	IP65 for gauge IP43 for electronics

Environmental

	Analogue	Digital
Storage Temperature	-40°C to +85°C	-20°C to +70°C
Operating Temperature	+5°C to +85°C	+5°C to +65°C
Operating Pressure (pneumatic only)	1 bar to 3 bar relative	
Shock	To maintain best performance the Flexure Gauge should be protected from excessive shock loads and dropping	

Electrical Interface

	Analogue		Digital
	LVDT	Half Bridge	
Energising Voltage	1 to 10 V rms		5 V ±0.25 VDC
Energising Frequency	2 to 20 kHz		Not applicable
Energising Current	3 mA/V at 5 kHz	1.2 mA/V at 10 kHz	55 mA at 5 VDC
Calibration Load	10 kΩ	2 kΩ	Not applicable
Sensitivity	200 mV/V/mm ±0.5% at 5 kHz	73.5 mV/V/mm ±0.5% at 10 kHz	



Accuracies quoted are through the gauge centreline.

Unplugged (free lead) and other specifications available on request.

¹ The Linearity Specification includes errors due to both linearity and sensitivity. Other manufacturers may quote these errors separately.

Ordering Guide for Flexure Gauge Components

All gauges are supplied configured as spring push. The Flexure Gauge is inclusive of integral sensor but does not include the tool holder, tip carrier or tips. These must be ordered separately.

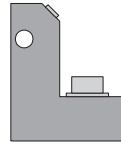
	Tips	With industry standard M2.5 thread. See page 98/99 of our Catalogue 02 or download the PDF file for the tip range from www.solartronmetrology.com
	Tip Carrier	20mm version - Part Number 208221/20 30mm version - Part Number 208221/30 40mm version - Part Number 208221/40
	Tool Holder	Part Number 804797-SX

Digital or Analogue Flexure Gauge

Product Type	Analogue		Digital
	LVDT	Half Bridge	
Axial Cable Outlet			
Forward Spring	AU/1/S	AU/1/SH	DU/2/S
Reverse Spring	AU/1/R	AU/1/RH	DU/2/R
Reverse Spring Pneumatic	AU/1/P	AU/1/PH	DU/2/P
Radial Cable Outlet			
Forward Spring	AUR/1/S	AUR/1/SH	DUR/2/S
Reverse Spring	AUR/1/R	AUR/1/RH	DUR/2/R
Reverse Spring Pneumatic	AUR/1/P	AUR/1/PH	DUR/2/P



United Kingdom
Solartron Metrology
Steyning Way
Bognor Regis
West Sussex
PO22 9ST

Tel: +44 (0) 1243 833333
Fax: +44 (0) 1243 833332
sales@solartronmetrology.com

U.S.A
Solartron Metrology
915 N.New Hope Road
Suite C
Gastonia
NC 28054

Tel: +1 704 868 4661
Fax: +1 704 868 8466
usasales@solartronmetrology.com

Germany
Solartron Deutschland GmbH
Wittekindstrasse 12
45470
Mülheim an der Ruhr
Deutschland

Tel: +49 (0) 208 31 026
Fax: +49 (0) 208 31 441
vertrieb@solartronmetrology.com

France
Solartron Metrology
Z.I. du Bois Chaland
2 rue du Bois Chaland
CE 5611 Lisses
91056 EVRY CEDEX

Tel: +33 (0) 1 69 64 47 47
Fax: +33 (0) 1 69 64 47 49
france@solartronmetrology.com

Agent and Distributor details available at www.solartronmetrology.com



Q 09540

Solartron pursues a policy of continuous development. Specifications in this document may therefore be changed without notice.

Orbit is a registered trademark or trademark of Solartron Metrology Ltd.

